

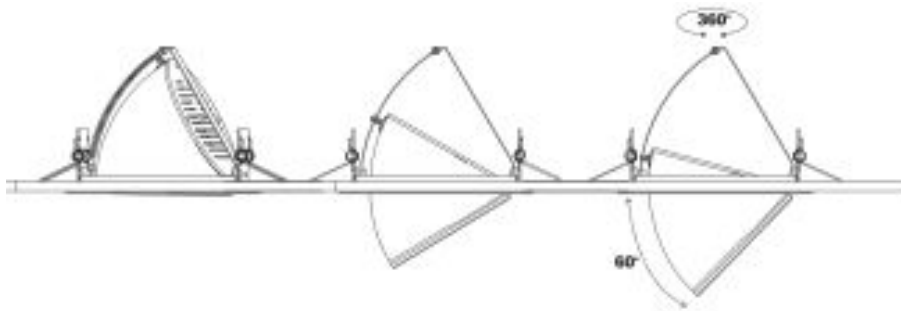

## 510T tilting downlight

The exquisite and noble outlook of NOVETE® 510t tilting recessed downlight is a high intensity luminaire designed for high-end concourse, shops, billboards, buildings and sculpture lighting applications. It could be freely tilted 360 degree horizontally and 60 degree vertically casting towards the specific object.



### General Characteristic

Material of housing	Die-cast aluminium alloy
Size overall	Ø185 x 150mm
Cut-out size	Ø175mm (approx. 7 inches)
Reflector	Ellipsoidal aluminium
Rated life span	50000 hours (accumulative)
Ingress protection	IP44
Tilting (horizontal)	360 degree
Tilting (vertical)	60 degree
Industrial standard	IEC 62384 / LM-80
Certification	CE, RoHS

### Light Characteristic

Light source	EPISTAR COB
Color rendering index	CRI≥80 Ra
Color temperature	3200K (K3); 4200K (K4); 6500K
Luminous efficacy	90 lumen per watt
Beam angle	30 degrees
Uniformity (uO)	>0.4
RF interference	Free
Standard function	Non-dimmable
Dimmable (dimmer switch)	TRIAC driver (optional)
Dimmable (pre-set dimming)	Potentiometer driver (optional)

### Electrical Characteristic

Input power	85~265VAC, 50/60Hz
Power supply	Built-in LED driver
Power factor	≥0.9
Operation temp	-20°C ~+50°C
Overload protection	95%~108% constant current limiting, auto-recovery
Over voltage protection	110%~140% rated output voltage
Operation humidity	95% Rh @-20°C to 50°C
Wire interface	No polarity
Safety standards	UL60950-1, UL1012, TUV EN60950-1, EN61347-1-13 61347-2-
EMC standards	EN55015, EN55022 class B, EN61000-3-2 class C, EN61000-4-2, 3, 4, 5, 6, 8, 11, EN50204, EN61547

### Product Specification

Model #	Power		Lumen	Compatibility	
	Rated	System		CFL	HID
510T-COBW15Kx	15.0W	16.7W	1200~1350lm	36W	100W
510T-COBW20Kx	20.0W	22.2W	1600~1800lm	50W	150W
510T-COBW25Kx	25.0W	27.8W	2000~2250lm	85W	250W
510T-COBW30Kx	30.0W	33.3W	2400~3700lm	120W	350W

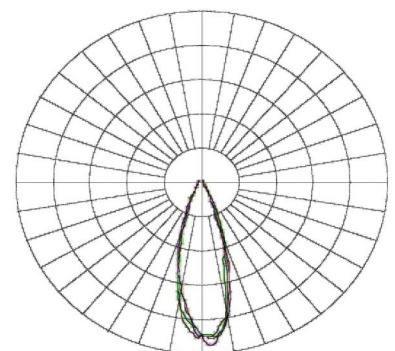

Typical Spectral Distribution