

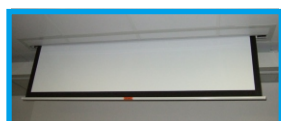

Features

- Fully Concealed when not in use
- Suitable for all kinds of false ceiling
- Compact, Light weight and Beautiful Finishing
- Ease of installation
- Adjustable setting kit desired up/down position
- Adjustable screen position horizontally
- All screens are supplied with black borders
- Every screen is supplied with remote control, electronic screen control and universal brackets

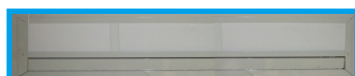

Model	Diagonal	Viewing Area	
<u>1:1 Format</u>			
CMS-1515	-	60" x 60"	1500 x 1500mm
CMS-1818	-	70" x 70"	1750 x 1750mm
CMS-2121	-	81" x 81"	2060 x 2060mm
CMS-2424	-	93" x 93"	2360 x 2360mm
CMS-2727	-	105" x 105"	2670 x 2670mm
<u>4:3 Format</u>			
CMS-1713V	86"	69" x 52"	1750 x 1310mm
CMS-2015V	100"	81" x 61"	2050 x 1540mm
CMS-2317V	116"	93" x 70"	2360 x 1770mm
CMS-2721V	135"	108" x 81"	2740 x 2060mm
<u>16:9 Format</u>			
CMS-1709H	79"	69" x 39"	1750 x 980mm
CMS-2011H	92"	81" x 45"	2050 x 1150mm
CMS-2212H	100"	87" x 49"	2210 x 1240mm
CMS-2313H	106"	93" x 52"	2360 x 1330mm
CMS-2715H	123"	107" x 60"	2720 x 1520mm
<u>16:10 Format</u>			
CMS-1710W	81"	69" x 43"	1750 x 1090mm
CMS-2012W	95"	81" x 51"	2050 x 1290mm
CMS-2113W	100"	85" x 53"	2150 x 1350mm
CMS-2314W	110"	93" x 58"	2360 x 1470mm
CMS-2717W	127"	108" x 67"	2740 x 1710mm

***** For other screen sizes, please call for consultation.**

Specifications

Motor Type :	AC Tubular Motor; Silent Type
Motor Speed :	17 rpm
Operating :	120 deg. Celsius (thermostat cut off motor)
Fabric Roll Speed :	4.8 m/min
Screen Gain :	1.2
Viewing Angle :	160 degrees viewing cone
Screen Materials :	Matte White with fibreglass coating, Flame Retardant and fungus resistant
External Wired Control:	Normally open, momentary contact closure (voltage free)
IR Remote Sensitivity Distance :	Maximum 15 metres
Sensor Coverage :	160 deg. (horizontal) 150deg. (vertical)
Power Consumption :	121W
Current :	1.2 or 0.64 Amperes
Voltage :	100 - 120 VAC or 220 - 240 VAC, 50/60 Hz

Accessories



Electronic Screen Control



AVA-300

1 channel Infrared Remote control



AVA-315

Radio Frequency Remote control

Dimensions

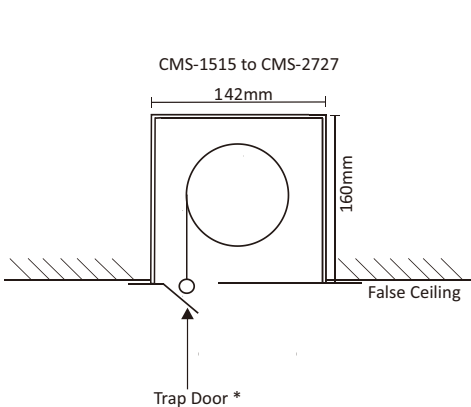

* Trap Door is optional

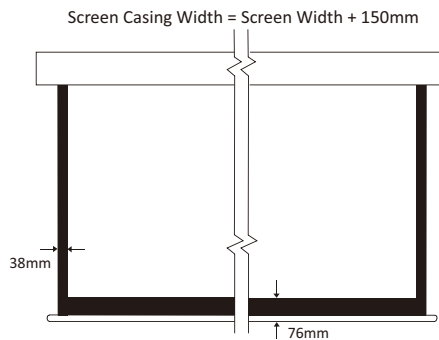

Screen with 3 sides black border

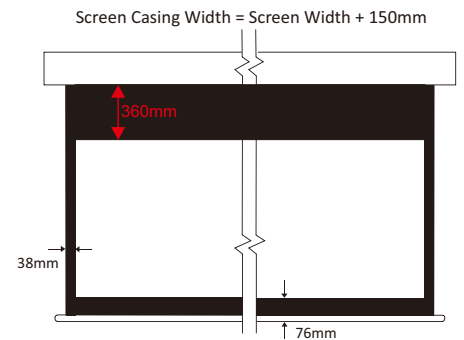

Screen with 4 sides black border

* For details dimension ,
please refer to technical specifications at
www.remacotech.com