

Installation Guide / Manual (AVA-ESC+)

ESC+



All controls support 230V/50Hz

AVA-ESC+ Electronic Screen Control

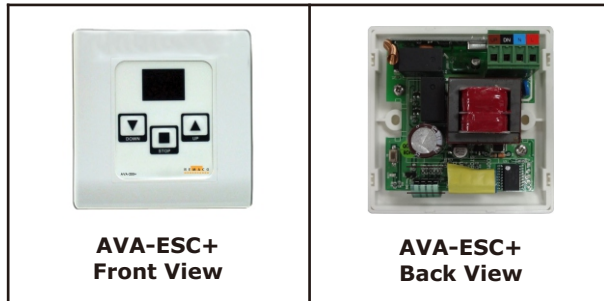

Specifications

Voltage AC (Volts)	230Vac 50Hz/60Hz
Power	1150 Watts
Frequency	RF : 433MHz IR : 38 KHz
Sensitivity Range	RF : 40 metres IR : 7 metres
Temperature (Celsius)	-20°C to -70°C

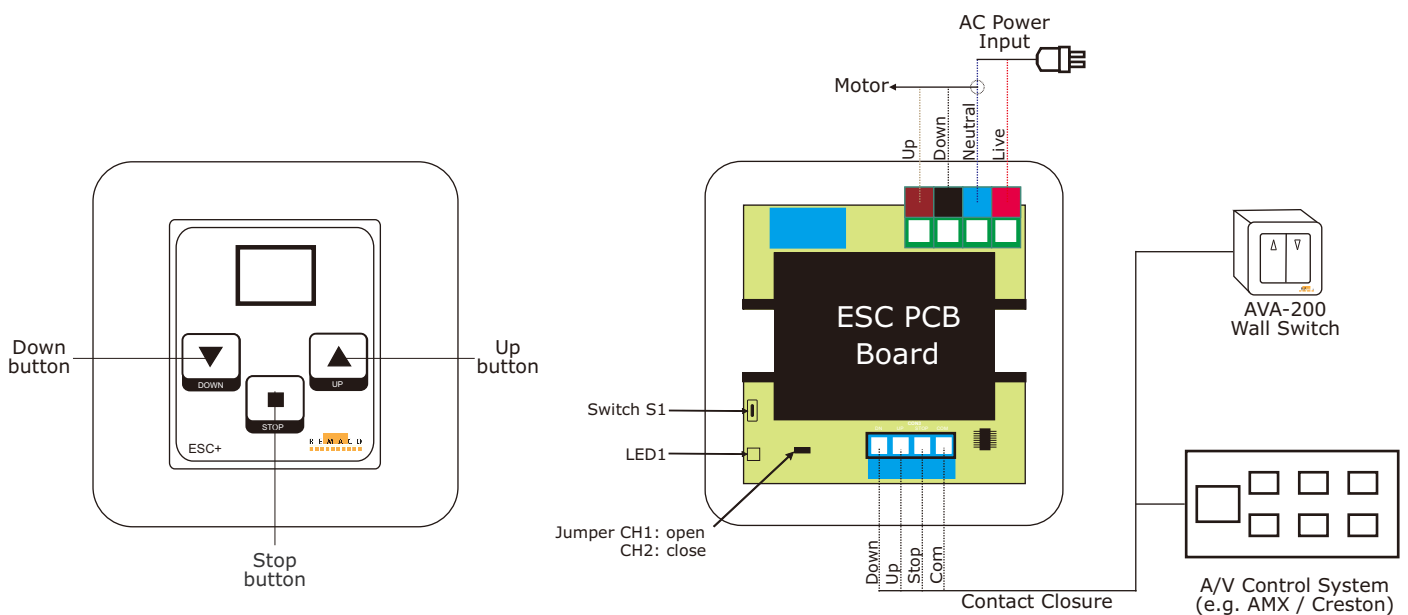

ESC+ compatible with AVA-315 1-Channel Radio Frequency Remote



**AVA-315
Radio Frequency Remote**

Pairing AVA-ESC+ with AVA-315-RF 1Ch

Learning Mode

- Step1. Press and Hold Switch S1 for 4 seconds.
- Step2. Release Switch S1 and motor step-move up/down, LED1 flash slowly.
- Step3. Press UP button on the RF remote, motor step-move again and stop.
- Step4. LED1 off and "Learning" is completed successfully.
- * NOTE: Make sure RF remote control is set close to ESC+ not further 20cm.
- **NOTE: If nothing is pressed within 20seconds, the learning mode will disable and back to normal mode.

Delete Mode

- Step1. Press and Hold Switch S1 until the LED1 flash fast.
- Step2. Release Switch S1.
- Step3. Press Switch S1 again within 7seconds.
- Step4. LED1 off, "Delete" mode is completed successfully.