

Installation Guide (For BKT-581 & BKT-586)

BKT-581 & BKT-586

Important Notes:

All Plasma / LCD TV brackets are thoroughly inspected and fully tested operational in factory.
 We accept no liability whatsoever for any losses due to improper operation, or any unauthorized alternation.
 All trademarks contained in this installation guide are the property of their respective owners.

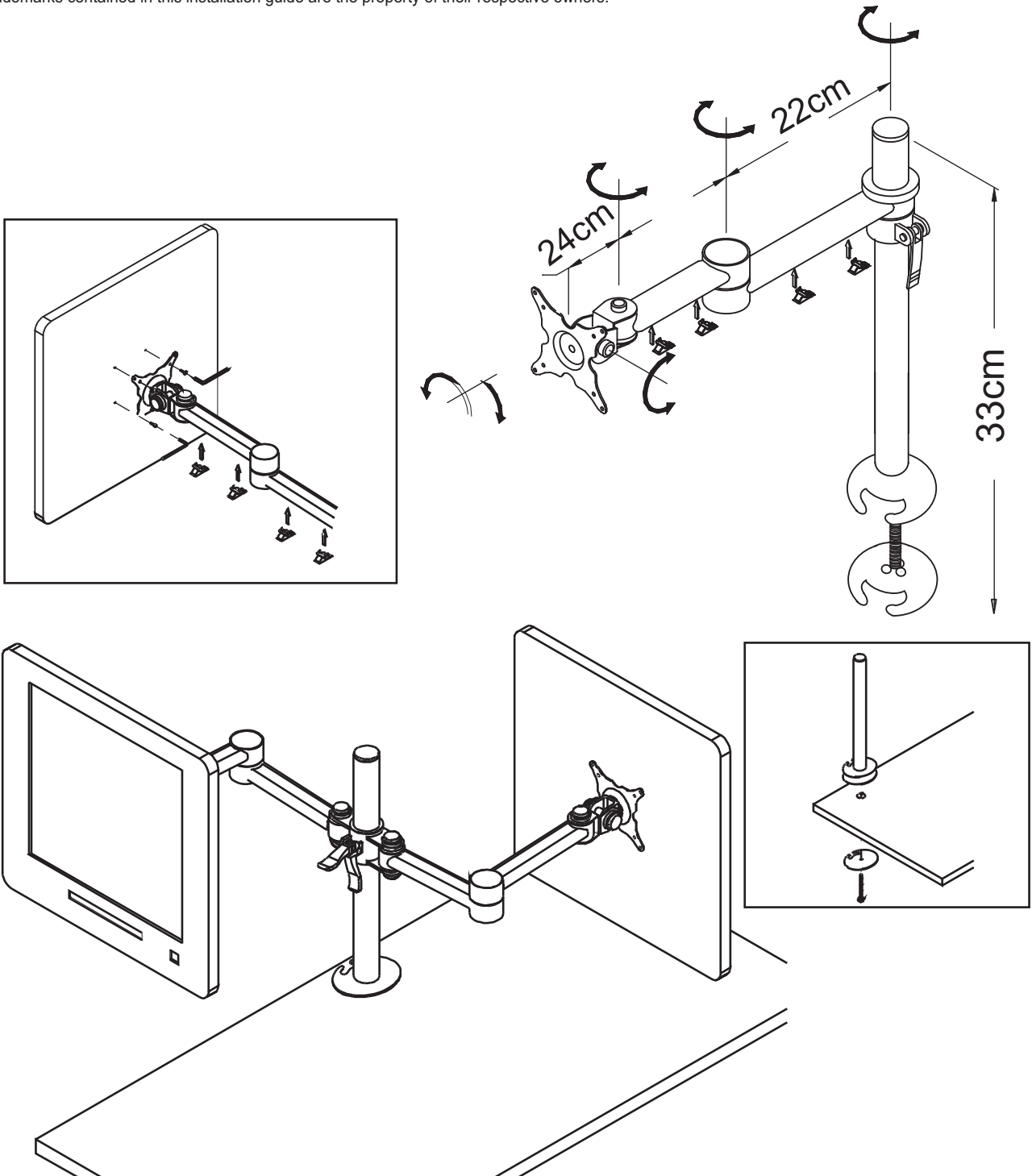

Accessories for mounting LCD Screen to BKT-581 & BKT-586

- M4x10 Cap Screws (4 Nos/8 Nos)
- No.13 Spanners (2 Nos)
- Allen Key (1 Nos)