

Installation Guide (For PSB-20A)

PSB-20A

Important Notes:

All spider brackets are thoroughly inspected and fully tested operational in factory.
 We accept no liability whatsoever for any losses due to improper operation, or any unauthorized alternation.
 All trademarks contained in this installation guide are the property of their respective owners.

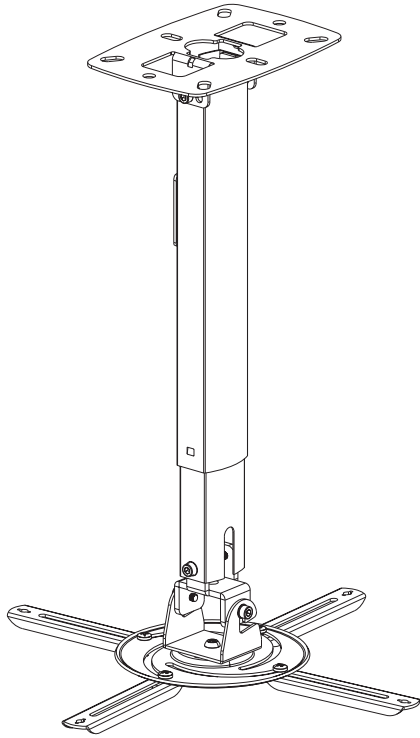

M4X20MM 1 (4PCS)	M5X20MM 2 (4PCS)	M6X20MM 3 (4PCS)	
4 (4PCS)	5 (1PCS)	6 (4PCS)	
7 (4PCS)	8 (4PCS)		

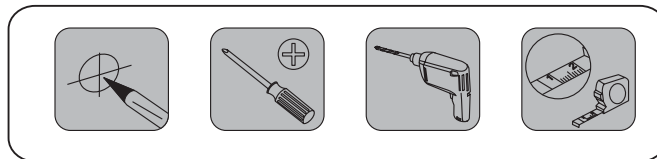

STEP 1

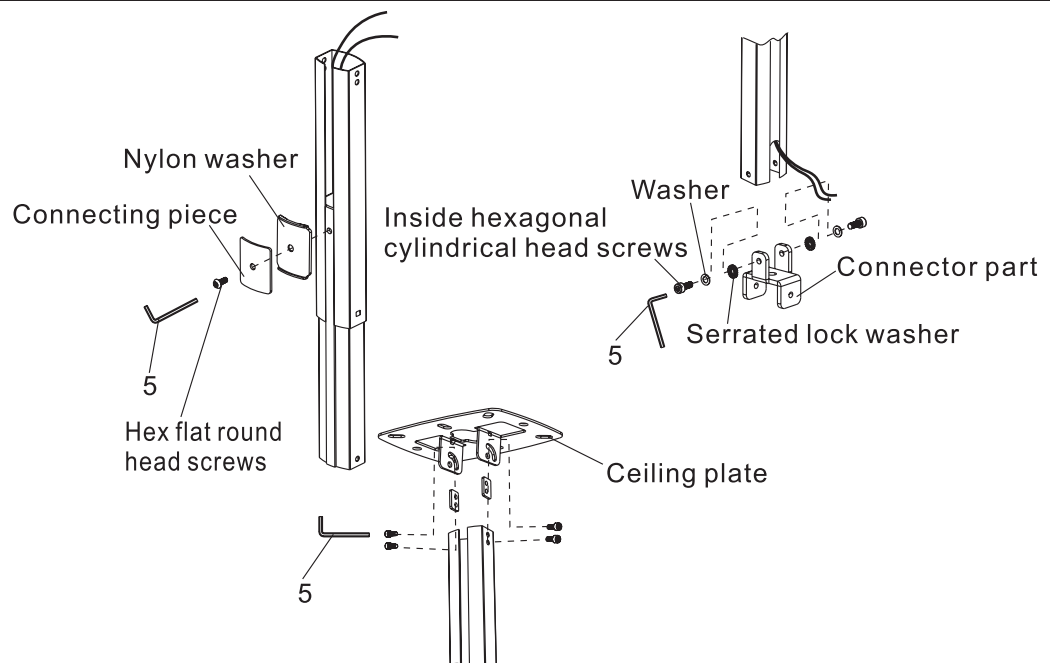

STEP 2-A

Solid concrete mounting

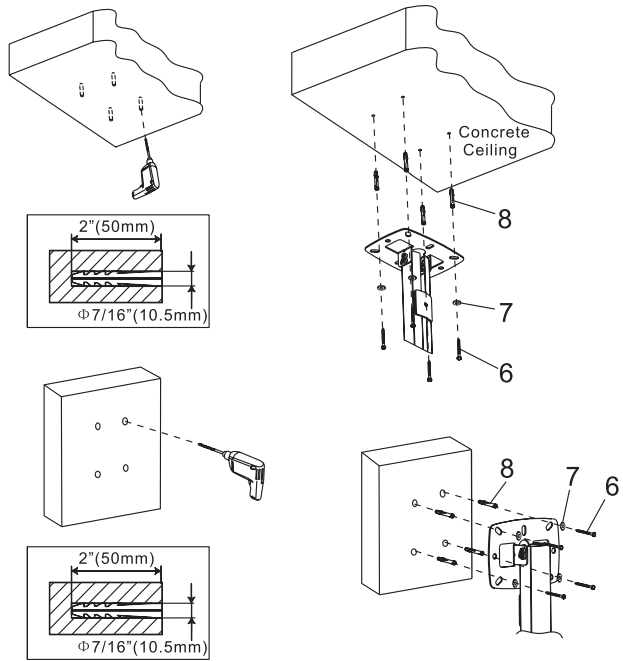

STEP 2-B

Wood Stud Mounting

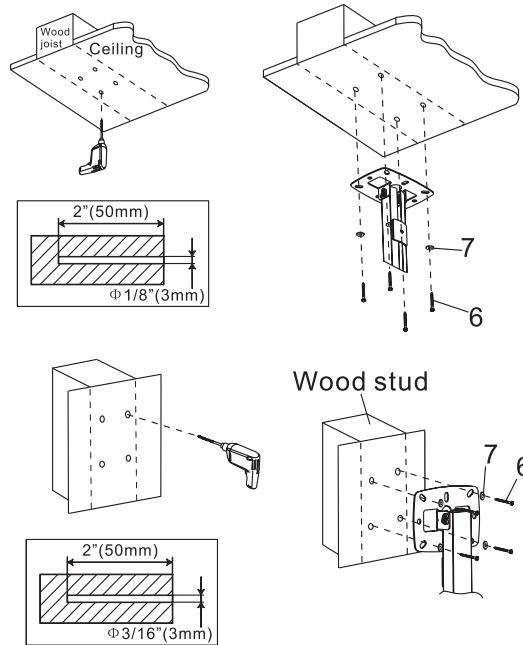

STEP 3

Attaching Brackets To Screen

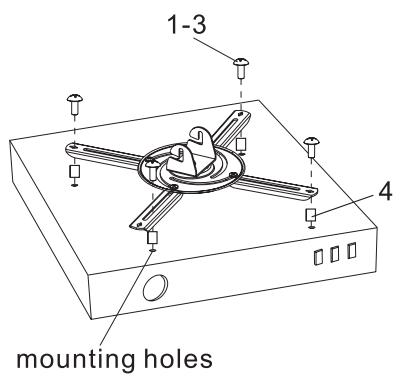

STEP 4

